

500A-MB EXCELLENT SERIES



- Heavy duty free standing disposer
- Designed for batch feed of food waste
- Disposer outlet can be positioned to suit existing drain installation
- Delivered ready for installation to existing water, drain pipe and electricity
- Compliant with IMO MARPOL 73/78 ANNEX V for disposal of ground food waste

Disperator food waste disposers are used in galleys and kitchens around the world, providing an efficient and immediate removal of food waste whenever it arises. Thereby improving hygiene in the working environment, eliminating bad odors and bacteria formation and minimizing manual handling.

Our product range is designed with the user's needs in focus and meets the modern requirements for handling food waste. The quality grinding unit with hardness from specially cast steel alloy, together with the unique sealing design between grinder and motor, ensure years of reliable operation and low maintenance cost. The disposer's life span is extended further by the outer housing of stainless steel EN 1.4301 (AISI 304) and protection class IP55 for electrical components.

The MB-cabinet with integrated food waste disposer is installed as a separate unit, eliminating mounting into existing interior, and is delivered ready to be connected to existing flushing water, drain pipe and electricity. If needed, it is possible to adjust the disposer's outlet to better fit the existing piping.

The wide range of disposer sizes makes it easy to adjust any installation to fit any workplace in a galley or kitchen.

The MB cabinet allows for food waste to be collected and ground in batches when required and the inlet is fully covered by a tight protection lid, preventing access to the grinding unit during operation, providing a splash back protection and reducing the risk of cutlery falling into the disposer by mistake. The lid is fitted with a safety interlock switch which stops the disposer when lifted. Other features of the lid are noise reduction during operation and the possibility to be used as an extra work surface serving its purpose even where space is limited.

The cabinet is delivered with a flushing nozzle, solenoid valve and line strainer already assembled for easy installation. Cold water will automatically flow through the nozzle when the disposer starts and flush the food waste into the grinder chamber and continue into the sewer system or connected tank.

Food waste disposers in the Disperator Excellent Series have the Declaration of Compliance issued by DNV verifying compliance with applicable sections of MARPOL consolidated edition 2011/2012 ANNEX V for disposal of ground food waste into the open sea.

Disperator AB

Mälurvägen 9, SE-141 71 Segeltorp, Sweden
Tel +46 8 724 01 60, Fax +46 8 724 60 70
info@disperator.se, www.disperator.se



MADE IN SWEDEN

Ref: 500A/MB/Prod/En/170919

500A-MB EXCELLENT SERIES

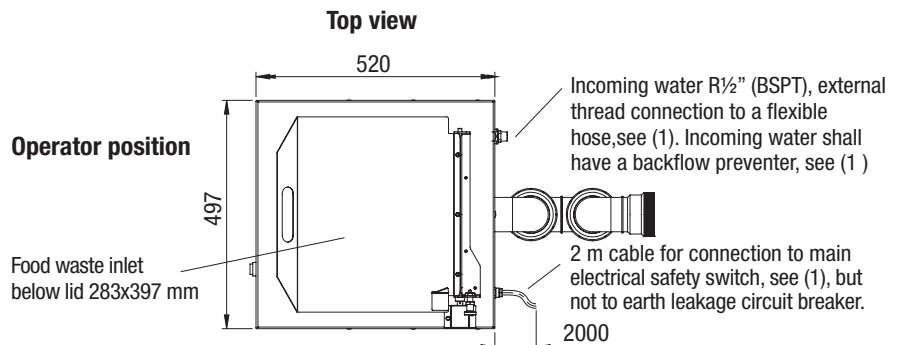
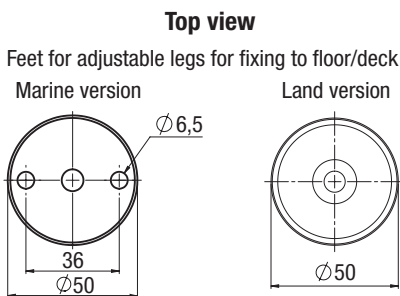
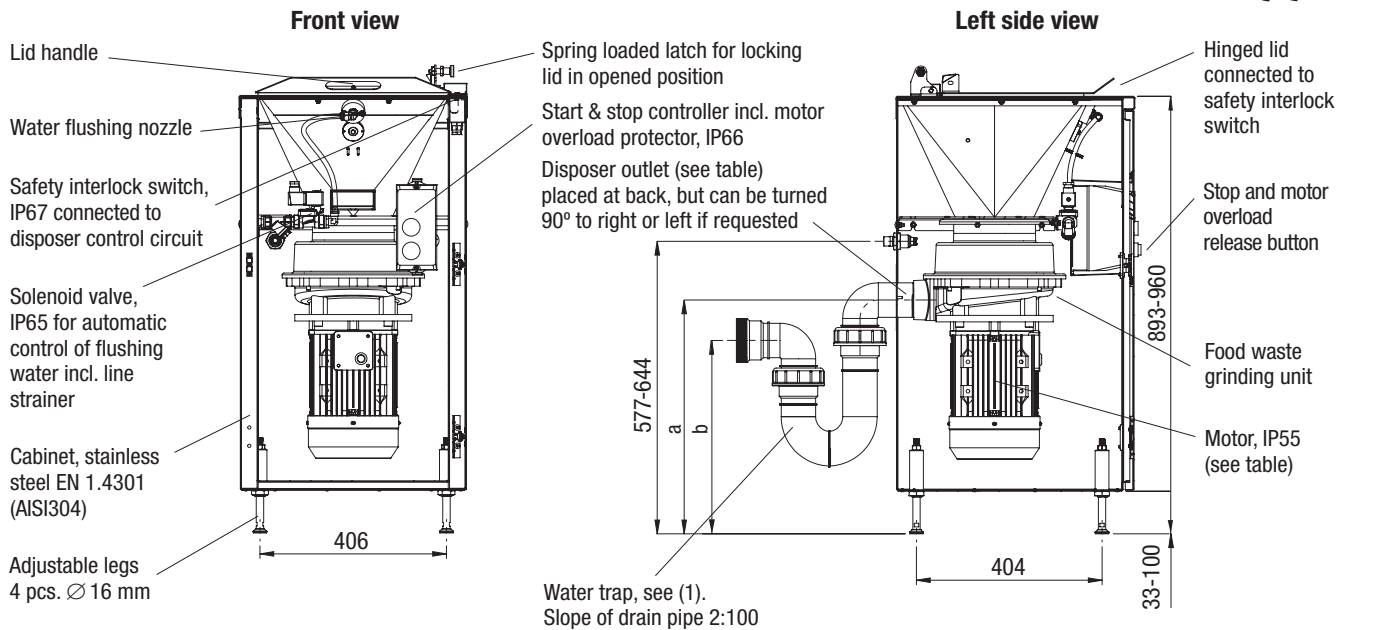

All measurements in mm

Technical Specification	510A	515A	520A	530A	550A	575A
Normal capacity, kg/hr	300	400	500	700	850	1000
Electrical power, kW	0,75	1,1	1,5	2,2	4,0	5,5
<i>Rated current, A to be set on the disposer motor protector for the following voltages:</i>						
400V / 3ph. / 50Hz	2,2	2,7	3,7	5,5	9,0	12,0
440V / 3ph. / 50Hz	2,2	2,7	3,7	5,5	7,5	10,0
480V / 3ph. / 60Hz	2,2	2,7	3,7	5,0	7,5	10,0
Other 3-ph. voltages available.						
Control voltage	For marine installation the same as motor voltage, for land installation 230V / 50Hz					
Fuse rating, slow	10 A	10 A	10 A	16 A	16 A	16 A
Characteristic for automatic fuse	D (slow)	D (slow)	D (slow)	D (slow)	D (slow)	D (slow)
Disposer outlet connection	G2" (BSPP), internal thread			G2 1/2" (BSPP), internal thread		
Height of disposer outlet (a)	← a = 485-551 →			← a = 450-516 →		
Ditto for water trap (b)	← b = 397-463 →			← b = 362-428 →		
(if ordered from Disperator)						
Gross / net weight, kg	64 / 55	65 / 56	69 / 60	83 / 74	86 / 77	92 / 83

Subject to change without notice

- Installation material needed but not incl. in standard delivery are:
 - main electrical safety switch,
 - reinforced flexible hose with minimum inner- \varnothing 9mm for cold flush water,
 - backflow preventer for flush water,
 - water trap for connection to disposer outlet.
 Can be ordered from DISPERATOR.
- User manual with installation and service instructions, wiring diagram, laminated operating instructions and laminated safety instructions included in delivery.

Disperator AB

Mälurvägen 9, SE-141 71 Segeltorp, Sweden
 Tel +46 8 724 01 60, Fax +46 8 724 60 70
 info@disperator.se, www.disperator.se