



HYDROMATIC®

Pentair Water

SUBMERSIBLE SOLIDS HANDLING PUMPS

Features and Benefits:

- **Oil Filled Motors**
Cooler operating than air filled motors and continuous lubrication of the bearings for longer life
- **Slip Fit Stators**
For easy of service
- **Seal Cord Entrance**
Triple seal protection, prevents moisture entry for longer life



Also available in
hazardous location
construction.



Submersible Solids Handling Pumps

Hydromatic pumps are field proven, reliable pumps.

Dependable **HYDROMATIC**® submersible solids handling pumps

You can depend on **HYDROMATIC** pumps to provide years of reliable service. Currently, there are thousands of units operating trouble-free throughout the world.

As one of the oldest submersible pump manufacturers in the world, **HYDROMATIC** offers you field-proven pumps and systems for all your requirements.

HYDROMATIC provides a 5-year warranty with proper start-up report, the most comprehensive in the industry. We also supply complete technical support and ongoing engineering assistance for the life of the pump.

Installations:

Municipal

- Wastewater transfer
- Wastewater treatment plants
- Wastewater lift stations
- Subdivisions
- Airports
- Storm water

Commercial

- Building wastewater systems
- Wastewater
- Hospitals
- Motels
- Apartments
- Schools
- Churches
- Universities
- Campgrounds
- Amusement parks

Industrial

- Wastewater
- Sump
- Spray wash
- Stormwater



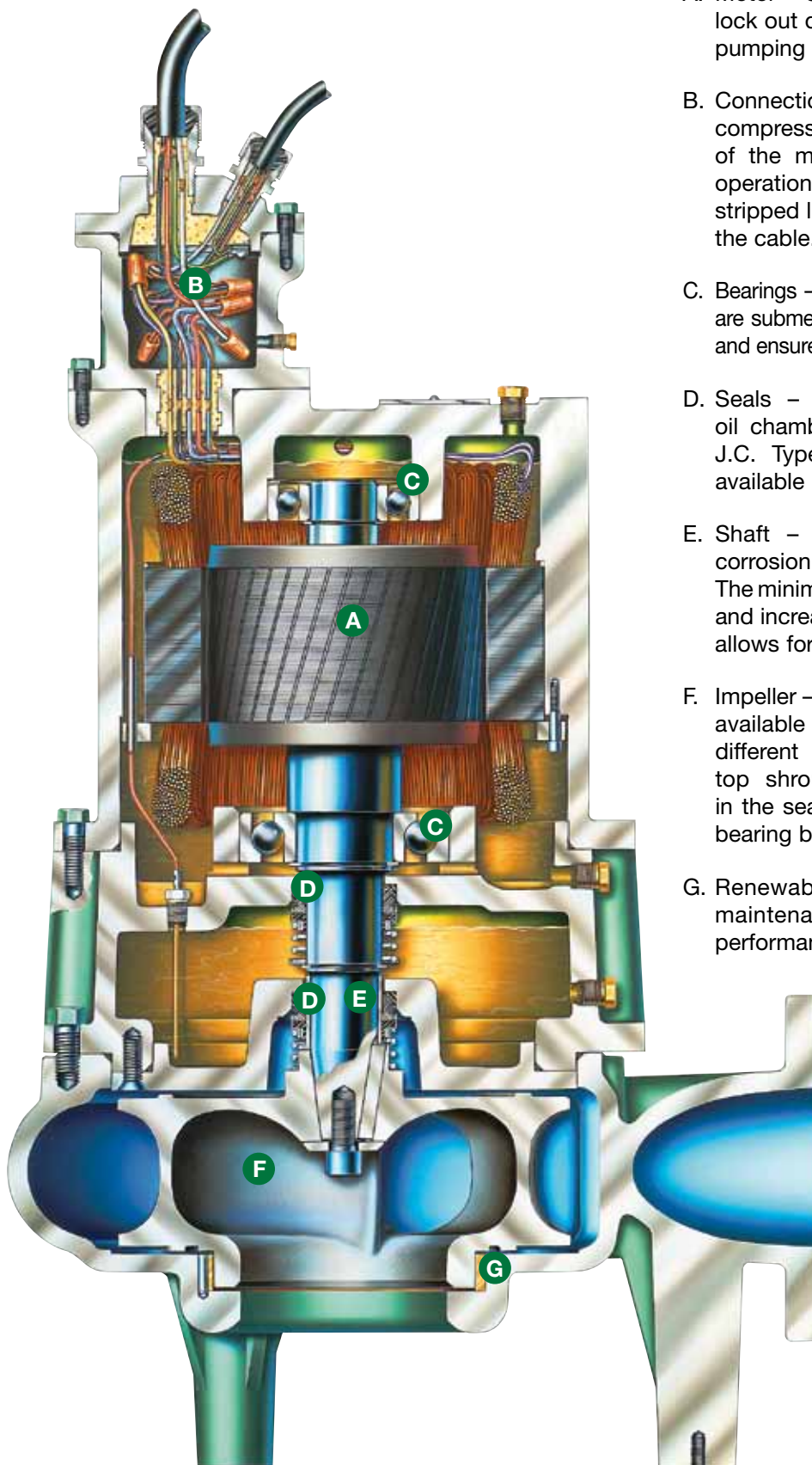

- A. Motor – Oil filled to efficiently dissipate heat and lock out damage moisture so you receive reliable pumping service.
- B. Connection Box – Two epoxy barriers and a compression fitting prevent water contamination of the motor area, assuring long-term reliable operation. Additionally, epoxy encapsulation and stripped leads positively eliminate “wicking” from the cable.
- C. Bearings – Heavy-duty upper and lower ball bearings are submerged in oil to provide permanent lubrication and ensure long service life.
- D. Seals – A dual seal system operates in an oil chamber to provide long pump service life. J.C. Type 21 seals are standard and readily available - optional materials upon request.
- E. Shaft – The stainless steel shaft eliminates corrosion and fatigue to give longer pump life. The minimum shaft overhang decreases deflection and increases bearing and seal life. Tapered shaft allows for easy removal of impeller.
- F. Impeller – Hydromatic Solids Handling pumps are available with a wide range of impellers for different applications. Pump-out vanes on the top shroud prevent the buildup of materials in the seal area and extend the life of the thrust bearing by significantly reducing axial thrust.
- G. Renewable Case Wear Ring – Reduces maintenance costs while maintaining the performance of the pump.

Submersible Solids Handling Pumps

Hydromatic pumps... work and keep working for years.

High Efficiency Saves You Money

Continuing submersible impeller design work and refinement spanning over 30 years gives you the most energy efficient pumps available.

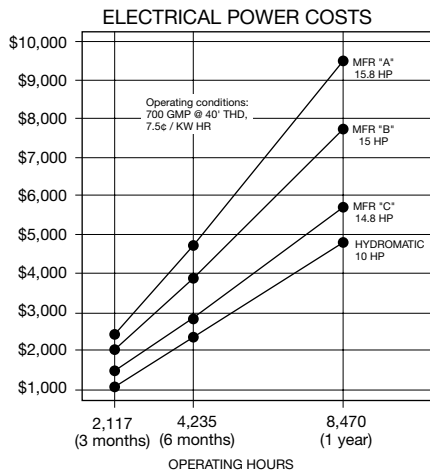

HYDROMATIC pumps save you money because of their high efficiency design.

The above chart compares electrical power costs of **HYDROMATIC** pumps with three other pump manufacturers. For example, with **HYDROMATIC** pumps you save \$4,628 dollars in one year of continuous operation compared with manufacturer "A". This more than pays for the pump!



Dependable Operation

The **HYDROMATIC** pump's oil-filled motor keeps the windings cool, eliminates moisture, and permanently lubricates the bearings, to provide reliable pumping service.

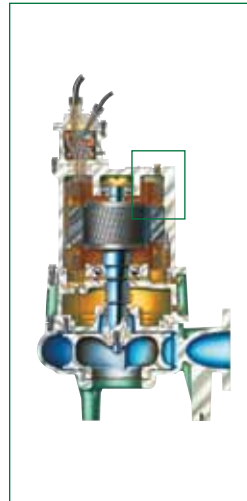

First, the oil bath keeps the motor and bearings cool by dissipating heat and maintaining the correct operating temperature.

The oil transfers heat generated in the motor windings to the housing where it is dissipated by the surrounding wet well media.

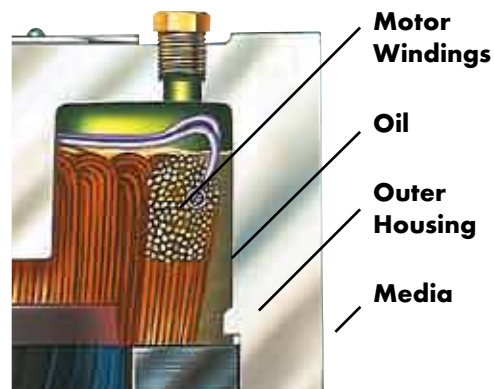

You get long pump life because the oil-filled motor dissipates heat from the windings, through the oil, to the outer housing and then the media.

Submersible Solids Handling Pumps

Second, the oil bath locks out airborne moisture contamination which destroys motors and bearings. Air carries moisture that condenses with temperature changes and causes premature motor and bearing failure.

Third, the oil bath permanently lubricates the bearings which minimizes heat and flushes contaminant away from bearing races.

Heat and contaminant cause grease breakdown. This breakdown leads to premature failure of grease-packed bearings supplied by other manufacturers. Oil-filled motors ensure dependable, reliable service!

Long-term Operation

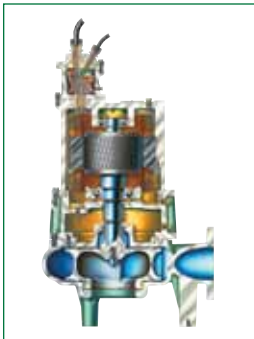

The Dual Seal System gives long pump service life.

The mechanical Dual Seal System protects the motor from water with one shaft seal at the top and one shaft seal below an oil chamber. The oil chamber provides lubrication for the seals and



S8LA



S4MX

traps any moisture that may leak through the lower seal. The upper seal operates entirely in oil.

The lower seal is “self-sealing” with pressure surges because it is located outside the chamber. Pressure surges from the volute push the lower seal tightly against the stationary face to prevent leakage into the oil chamber.

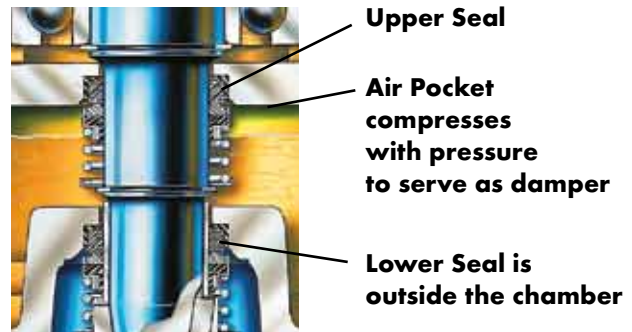

The mechanical dual seal system protects your motor from media contamination to provide you exceptionally long pump service.

HYDROMATIC pumps use high performance, low friction, long-lasting carbon-ceramic seals. Some manufacturers use very expensive seals that are available only from their own factory. **HYDROMATIC** pumps use repairable John Crane Type 21 mechanical seals that are available off-the-shelf worldwide. Tungsten-Carbide and Silicon-Carbide Seals are optional.

The dual seal design gives the pump exceptionally long pump service life by keeping pumped media out of the motor housing.

Submersible Solids Handling Pumps

Hydromatic pumps... save money and decrease downtime.

Decrease Downtime

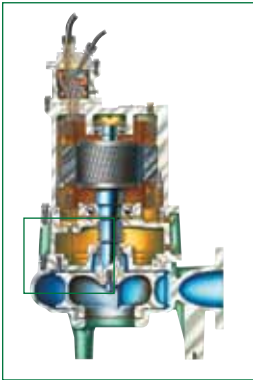

The moisture sensor, provided as standard on all solids handling pumps, saves money and decreases downtime by allowing you to take corrective action before an expensive bearing or motor failure occurs.

Some manufacturers put a moisture sensor in the motor area. Moisture is detected after it begins affecting the bearings and motor itself.

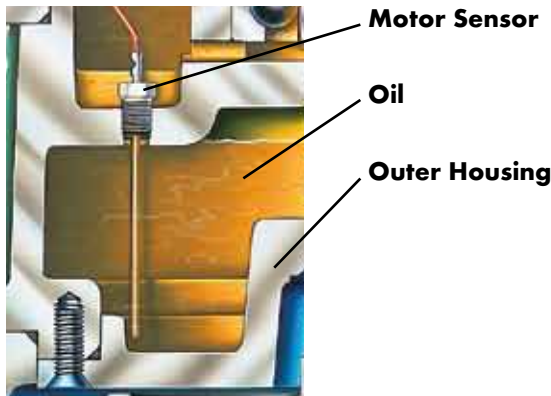

You get long pump life because the oil-filled motor dissipates heat from the windings, through the oil, to the outer housing and then the media.



S3HRC



S4M

HYDROMATIC pumps incorporate an internal moisture sensor that detects the presence of moisture in the oil chamber. The sensor's signal to the warning system lets you know that the lower seal is beginning to leak.

This allows you to schedule maintenance within 2 to 4 weeks while the pump continues to operate.

The moisture sensor allows you to perform maintenance at your convenience instead of reacting to an emergency breakdown.

Reliable Operation

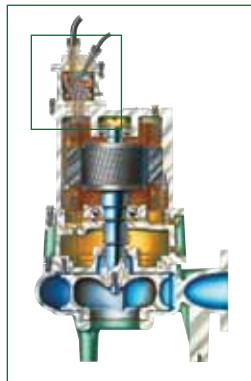

Three barriers provide triple protection against motor-damaging water.

Two epoxy barriers and a compression fitting keep water out of the motor so you get long-term, reliable operation.

A water-tight seal at cable entry is ensured with a single trumpet shaped elastomer grommet flanked by a washer and compression gland.

The top epoxy barrier keeps water out of the connection box, and the lower barrier keeps moisture out of the motor area when the cord is disconnected.

Leads going through both epoxy barriers are stripped down to bare wire at staggered intervals and each lead is individually separated. This lead-encasing design prohibits any wicking or capillary water movement inside the cord.

Submersible Solids Handling Pumps

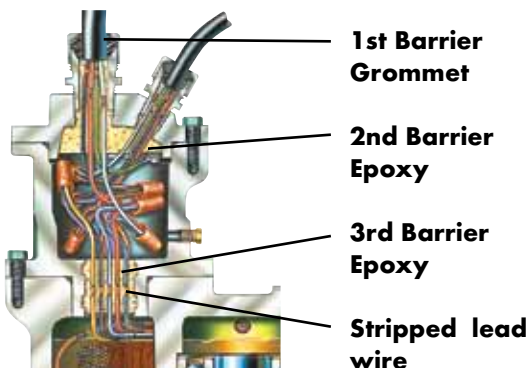

Three barriers ensure a dry motor for long-term, reliable operation.

There is no terminal board to crack and invite motor burnout.

HYDROMATIC epoxy barriers are the most proven sealing method available.

Low Maintenance

HYDROMATIC pumps are virtually maintenance free because the oil-filled design keeps the motor and bearings both fully lubricated and operating in the proper temperature range for very long life. You schedule and perform periodic maintenance for bearings and seals less often than required by other manufacturers.

Easy-To-Service

The volute-mounted wear ring is easily replaceable. It is made of bronze or optional stainless steel to give you long impeller life. **HYDROMATIC** pumps use a true wear ring, not a media lubricated bushing used by some manufacturers.

The top pullout design makes it easy to disassemble the pump in one operation in order to replace worn components, including the impeller. This reduces repair time and downtime.

The tapered shaft available on models S4M and larger allows the impeller to be easily removed without special tools.

Stators are easily field replaceable with standard tools. Stators are reliably held in place with keys and a clamp ring. Some manufacturers with press fit stators require complete shop facilities for replacement.

The H Series

The H series solids handling pumps provide greater pump efficiency and steeper non-overloading performances while passing up to a full 3" spherical solid as is required by the "Ten States Standards" policy for submersible solids handling pumps. These pumps are available with horsepower ratings from 7.5 to 15 and speeds up to 1750 RPM. These pumps are also available with a dependable **HYDROMATIC** pultruded lift-out rail or metal-to-metal lift-out rail system.

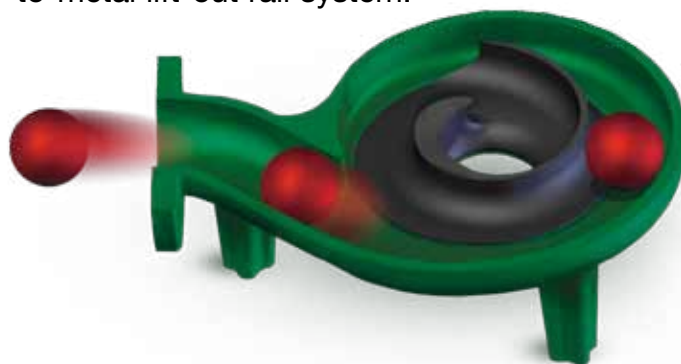

The enhanced geometry of the mono-vane impeller creates a smoother design, allowing the **HYDROMATIC** H series to pass a full 3" spherical solid while maintaining high efficiency.

Submersible Solids Handling Pumps

Hydromatic pumps... meet your special requirements.

Hazardous Location Pumps

Class I, Division 1,
Group C and/or D

When government regulations or area classifications require hazardous location pumps, you can depend on **HYDROMATIC** submersible solids handling pumps.

You Get Rugged, Safe Pumps

Now you can get certified hazardous location pumps for applications such as sewage wet wells where flammable gases exist.

You Get Reliability and High Efficiency

With **HYDROMATIC** hazardous location pumps, you get the same reliability and high efficiency designed into the non-hazardous location pumps. Plus, you get added safety advantages with FM approved, hazardous location, **HYDROMATIC** pumps.

Reliable, safe operation is ensured because all castings are inspected for porosity before, during and after machining. After assembly each hazardous location pump is thoroughly inspected to ensure reliable performance.

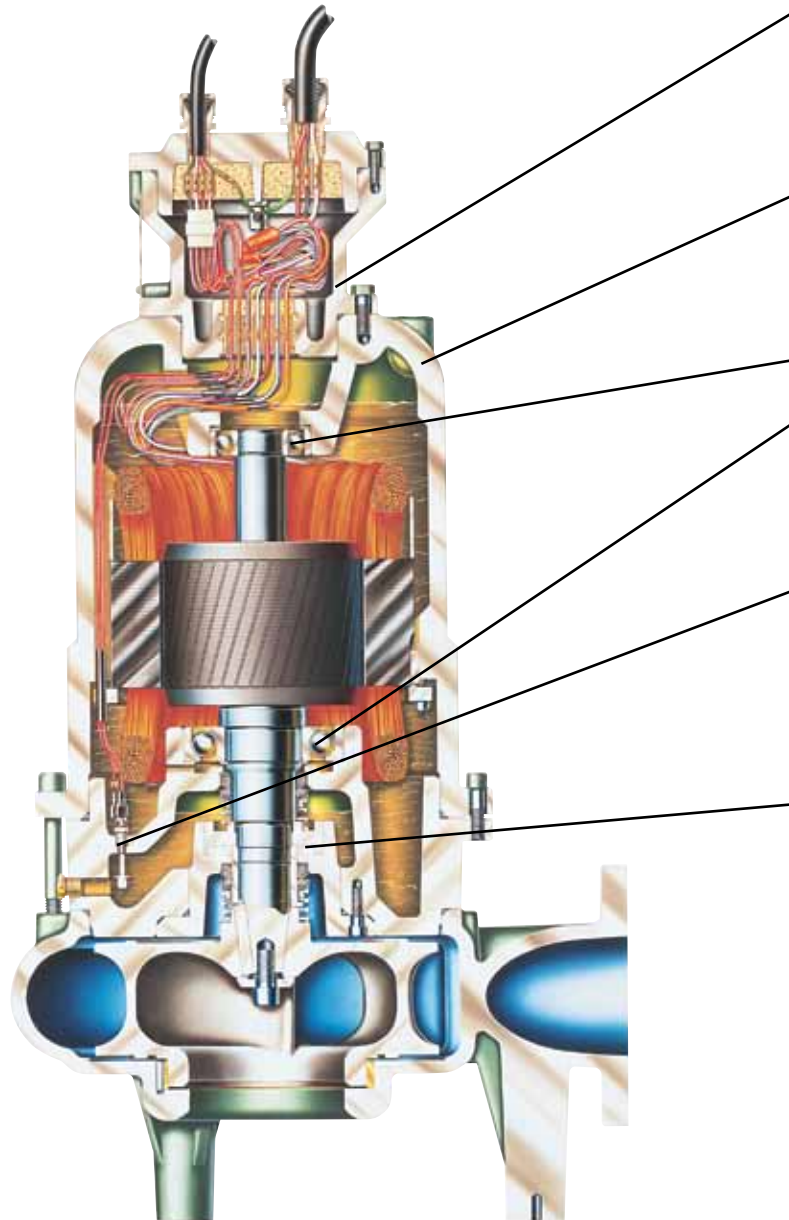

S4LVX

Submersible Solids Handling Pumps

FLAME-PROOF JOINTS - Flame-proof joints have 1-1/4" flame paths. These close tolerance joints prevent any internal spark or fire from escaping into the environment.

MOTOR HOUSING - The hazardous location housing wall is thicker throughout the case to give you extra containment capability.

HEAVY-DUTY BEARINGS - HYDROMATIC pumps provide you heavy-duty bearings (minimum B-10 life of 50,000 hours) for long pump life.

2 MOISTURE SENSORS - Two moisture sensors in the oil chamber provide extra security. The sensors are electrically isolated and made with stainless steel connections and stainless steel probes.

LABYRINTH JOINT - The special labyrinth joint gives you added protection by preventing flame or spark travel to the media being pumped.



Recessed Impeller Option

HYDROMATIC pumps are available with recessed impellers which are virtually impossible to clog and they perform up to shut-off head without damage.

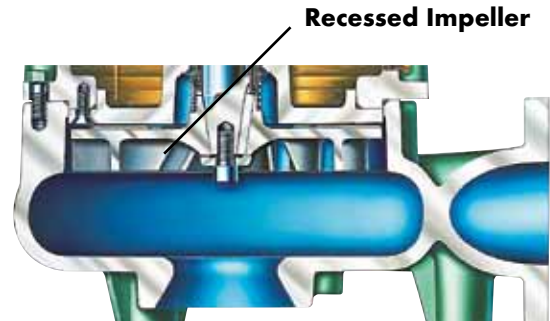

Recessed impeller pumps are ideal for a broad range of sewage and special waste-handling situations including high head and low flows and where large solids are present.

The recessed impeller creates a liquid vortex in the volute which directs all spherical solids, slurry, sludge, grit, stringy or fibrous material through the pump without clogging. The pumps are virtually impossible to clog.

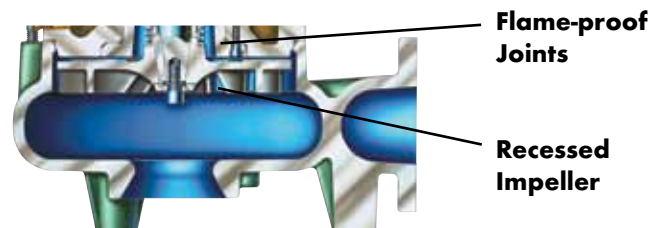

You can also order the hazardous location **HYDROMATIC** pump with the recessed impeller that's virtually impossible to clog.

Submersible Solids Handling Pumps

Hydromatic pumps cover all your requirements.

1750 RPM

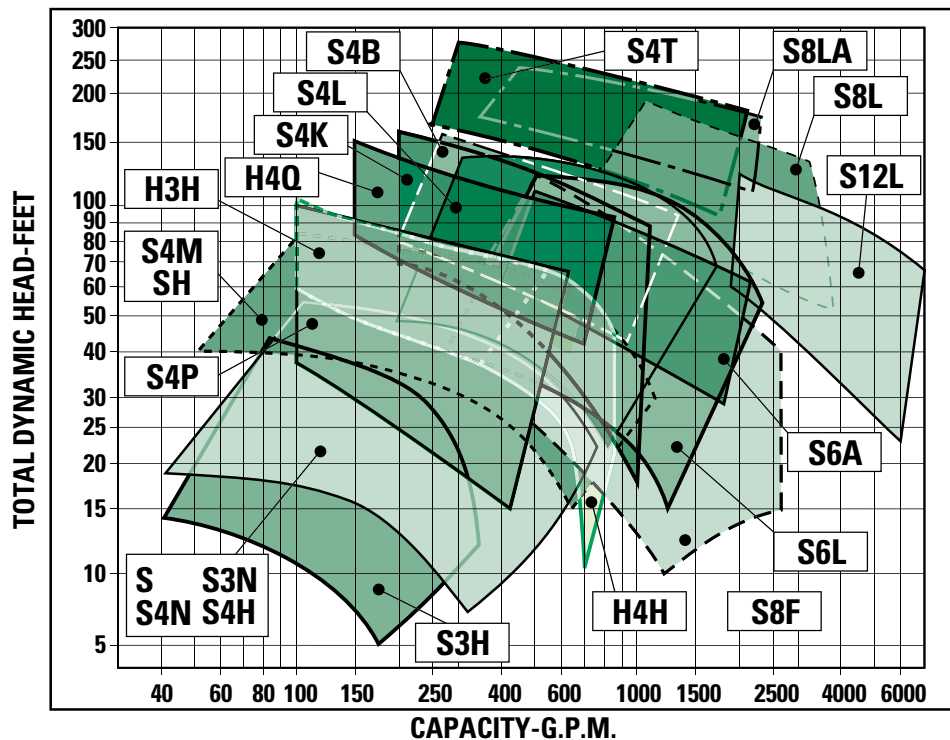

1150 RPM

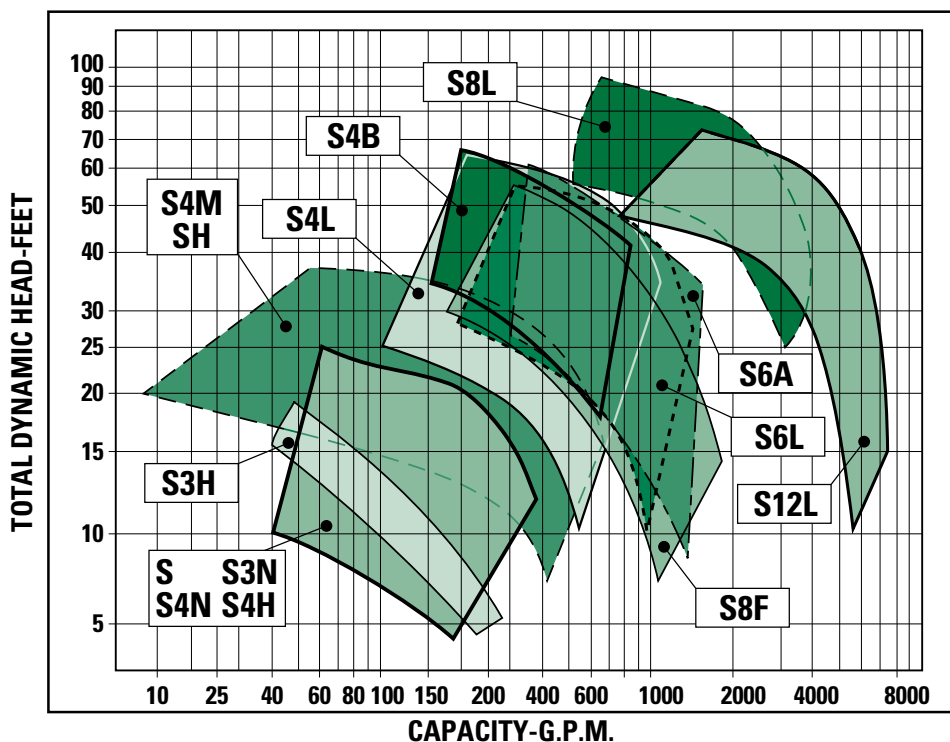

Submersible Solids Handling Pumps

Hydromatic pumps cover all your requirements.

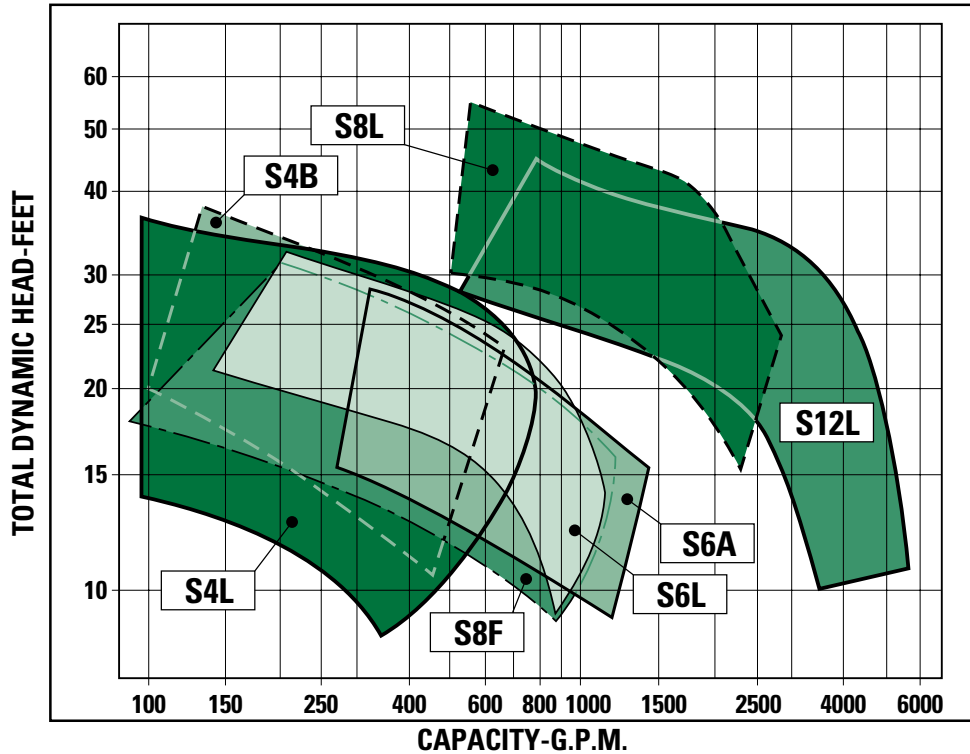

RANGE CHARTS FOR THE RECESSED IMPELLER

3450 RPM

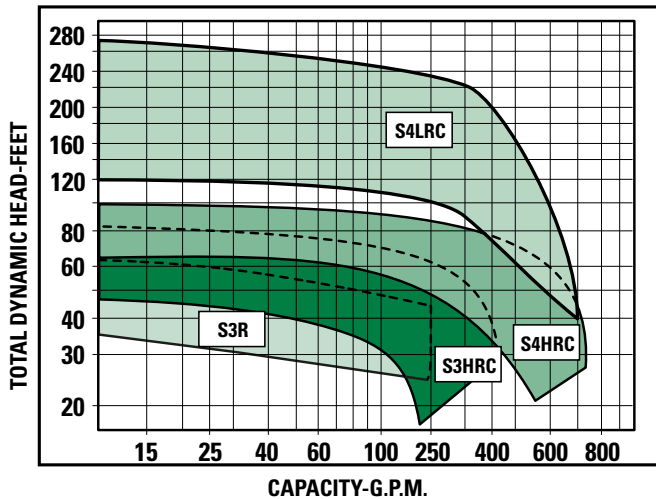

1750 RPM

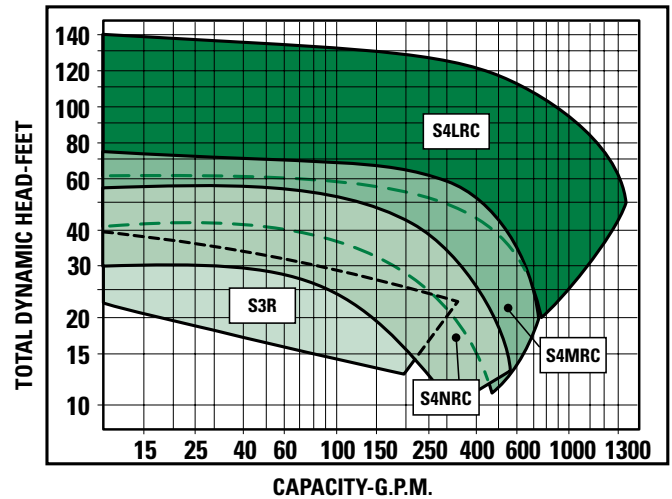

Submersible Solids Handling Pumps

System Operations

Rail Systems for Easy Pump Retrieval

To easily raise and lower your pump(s) for service and maintenance, you can choose from among three rail systems.

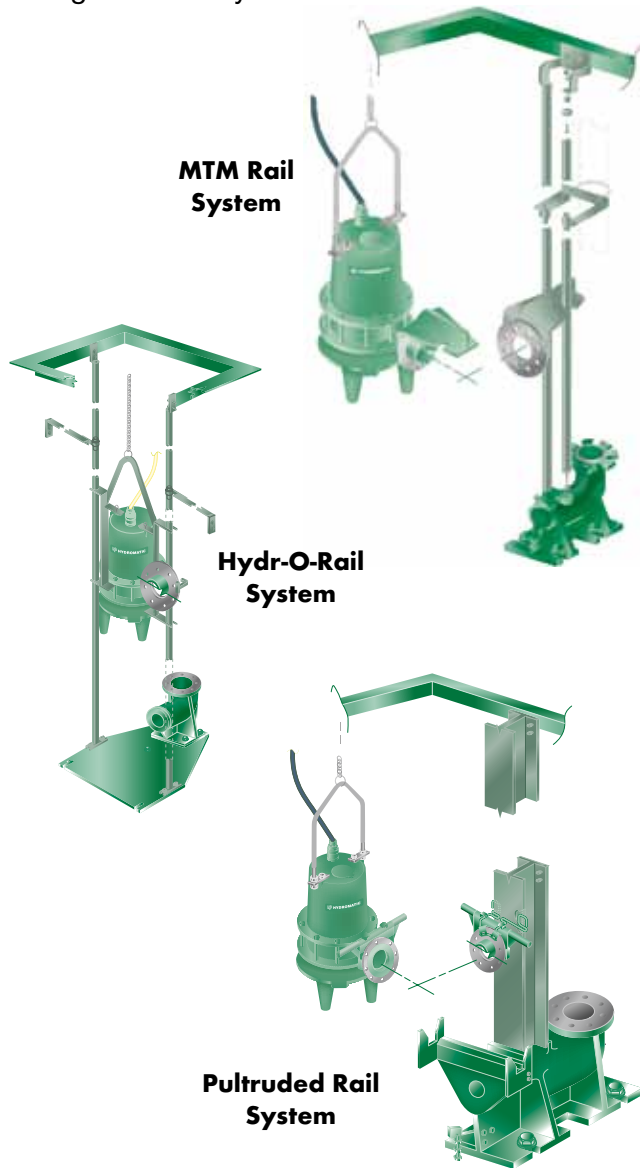

A New Generation

Custom built to your specifications and individually tested, the **HYDROMATIC NOVUS** Series is available in five different models: 1000, 1000 Plus, 2000, 3000 and 4000. The series starts with the dependable yet inexpensive **HYDROMATIC NOVUS 1000** Series which features basic relay logic controls in a quality NEMA 3R painted steel enclosure. The next model is the **HYDROMATIC NOVUS 1000 Plus** Series offering additional features in a NEMA 4X enclosure for Hydromatic 2HP grinder packages.

The **HYDROMATIC NOVUS 2000, 3000, and 4000** Series offer more advanced features. These series utilize state-of-the-art digital controllers that are optimized for submersible pumps in simplex, duplex or triplex wastewater lift stations.

Novus 2000 Simplex Controller Unit



Novus 2000 Duplex Controller Unit



NOTE: Hydromatic reserves the right to make revisions to its products and their specifications, and to this brochure and related information, without notice.



800 Airport Road • North Aurora, Illinois 60542 • Phone: 888-987-8680
3601 Fairbanks Avenue • Kansas City, Kansas 66106 • Phone: 888-416-9510
1101 Myers Parkway • Ashland, Ohio 44805 • Phone: 888-416-9513
8263 Florida Boulevard • Denham Springs, Louisiana 70726 • Phone: 800-219-9183
269 Trillium Drive • Kitchener, Ontario, Canada N2G 4W5 • Phone: 519-896-2163

www.hydromatic.com

E-02-6470 12/11 © 2011 Pentair Pump Group, Inc.